



# LIFT PIN

## Advantages:

- Unique handle design for easy grip
- Can be installed in either wet cast or dry cast concrete products
- Stop guide for accurate installation
- Can be used with spreader bar and chains, hooks or slings
- Working load limits of 5,500 and 7,500 lbs. per pin. Ultimate load is four times working load.



## Composition:

- Injection molded with durable polypropylene conforming to ASTM D-4101
- 1" or 1-1/8" diameter Grade 60 reinforcing bar conforming to ASTM A-615

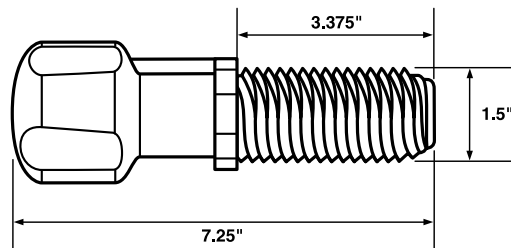
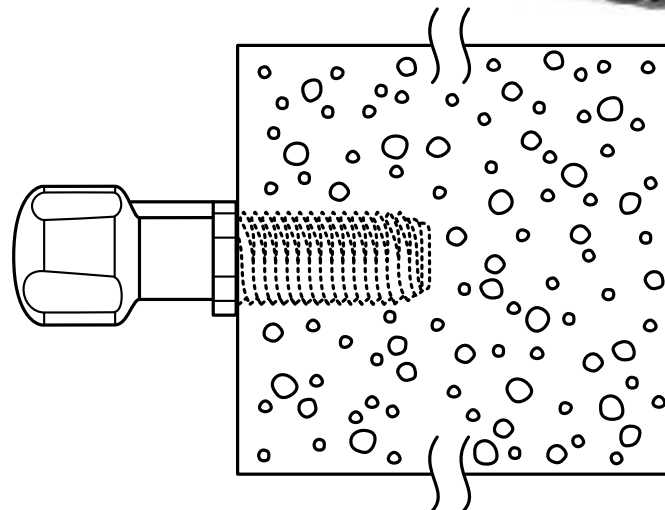



# LIFT PIN INSERTS

- Lift inserts are a single injection molded part, not two pieces solvent or sonic welded together. This guarantees a water-tight and vacuum-tight part.
- Outside rings to insure no infiltration or exfiltration along the outside of part.

## Easy to install:

- Standard lift insert fits on to locating pin inserted through outside form. For use with wet and dry cast method.
- Breakaway lift insert fits into locating ring attached to outside form. Collar breaks off during stripping of product. For use with wet cast method.

