



BOWCO Manhole Step INSTALLATION INSTRUCTIONS

Recommendations for: SETTING SOCKETS in VAULTS and OTHER STRUCTURES FOR DRIVE FIT STEP

Manufacturers with variable step locations or difficulty maintaining preformed step holes can use the specially designed BOWCO Socket to achieve this function.

Any casting equipment using an inner form will allow use of a simple template plate to set BOWCO Sockets, accurately spaced for use with BOWCO Steps. A perfect tapered hole is formed every time.

Sockets can be gang set with a template at any location in the vault or structure to step width and height spacing as specified by the buyer.

Template is a steel or plastic flat plate approximately 3/16" thickness. At the manufacturers option this plate should be either 12" or 15" wide and applicable length to fit the inner forms. Edges of template should be bevelled to allow easy removal from the concrete. Holes are drilled and countersunk for a 1/4"-20 thread 4" long flat head bolt to specified step widths and height as determined by the buyer. Additional holes are required to be drilled and countersunk in template allowing it to be bolted to inner form or vault of structure forms. A washer

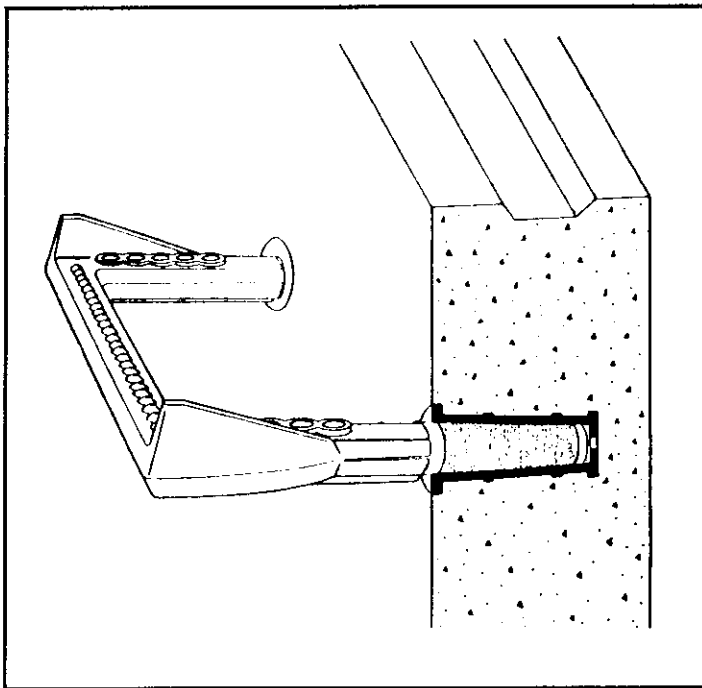
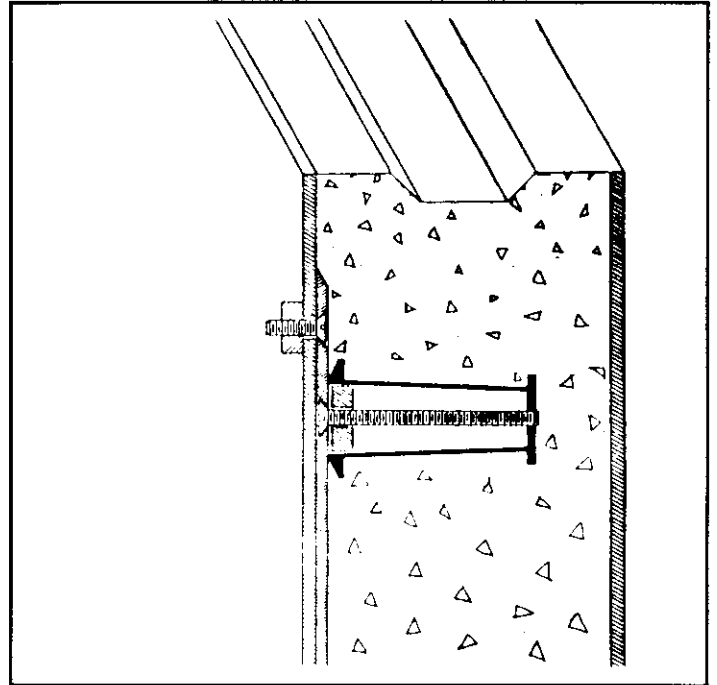

sleeve is recommended to hold the socket in place during placement of concrete.

After sockets are mounted on template, they should be checked for secure fit.

Template should be unbolted from the inner form before inner vault or structure form is removed. Then, screws holding the sockets are removed, allowing the template to be pried loose and removed from concrete.

Steps should only be installed after concrete has reached a minimum strength of 3,000 PSI.

We do not recommend the BOWCO Socket be used in conjunction with steam curing applications.

Simple Rules:

- Countersink holes for 1/4"-20 thread 4" long flat head bolts on 10" or 13" centers.
- Countersink holes to bolt template to inner form.
- Mount sockets and check for secure fit.
- Unbolt template from inner form before removing inner form.
- Cure concrete to a minimum of 3,000 PSI strength before installing steps.

BOWCO Industries, Inc.

(503) 653-9405 • (888) 232-9991