

# Polymer Threaded Inserts

For use in concrete

## Advantages:

Bowco Industries' Threaded Inserts are the most cost effective method for securing objects to precast and cast-in-place concrete.

- Corrosion Resistant
- Strong
- Lightweight
- Easy To Use
- Economical

## Versatile applications:

- Bolt equipment, racking or channel to vault walls
- Lift lightweight pieces
- Secure air conditioning units and other equipment to concrete pads
- Bolt metal or cast iron frames to concrete lids
- Suspend pipe and conduit from concrete panels
- Secure handles to burial vaults
- Many other uses

## Available sizes and working loads:

PART NO.	BOLT DIA.	THREAD N.C.	A (IN.)	B (IN.)	C (IN.)	WORKING LOAD (LBS.)
IN14R	1/4"	20	0.75	1.00	1.50	600
IN38R	3/8"	16	0.75	1.00	1.50	700
IN12SH	1/2"	13	0.67	1.10	1.50	1500
IN12ES	1/2"	13	0.75	1.25	1.50	1650
IN12S	1/2"	13	0.75	1.25	1.75	1650
IN12R	1/2"	13	0.75	1.25	2.50	2000
IN58R	5/8"	11	0.95	1.38	2.95	3400
IN34R	3/4"	10	1.00	1.63	3.20	3500

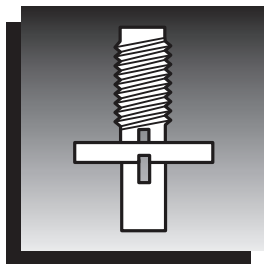
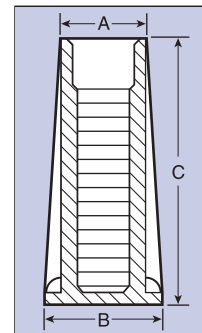

# Locators

For use with metal and wood forms

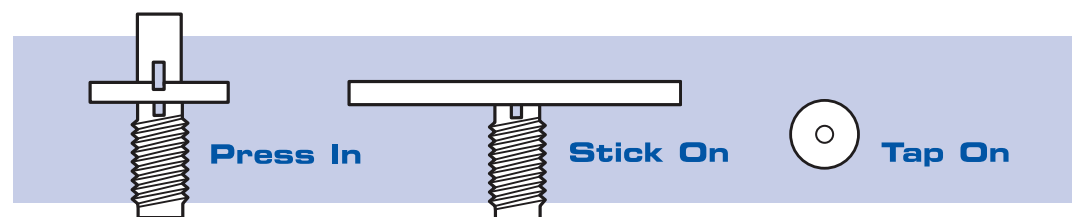

*There are no implied warranties of merchantability or of fitness for the particular purpose, and there are no other implied warranties of any nature whatsoever.*

(888) 232-9991  
www.bowcoind.com

# Installation

## PRESS IN

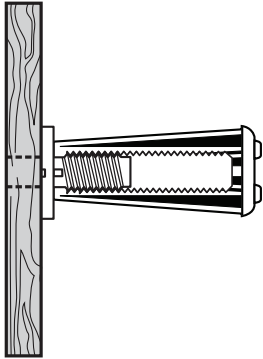

**1** Press into form wall.

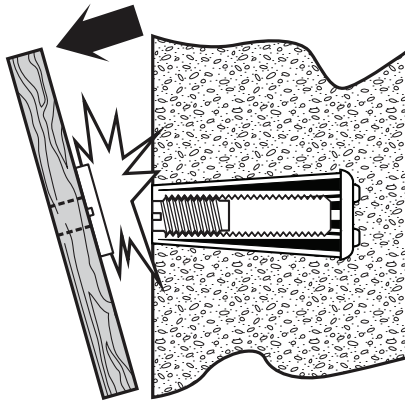

**2** Strip form.

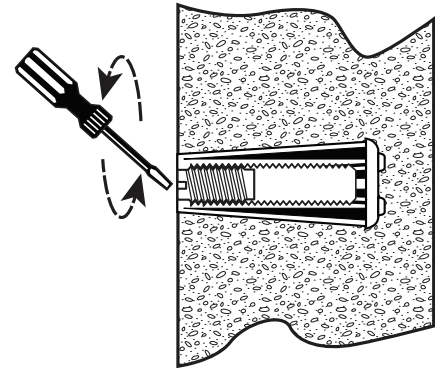

**3** Plug can be extracted with screwdriver

## STICK ON

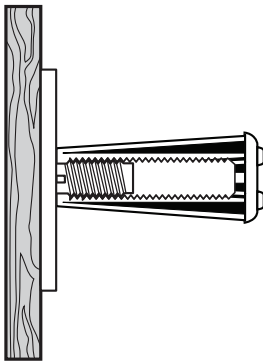

**1** Remove film from back. Stick on form wall with insert attached.

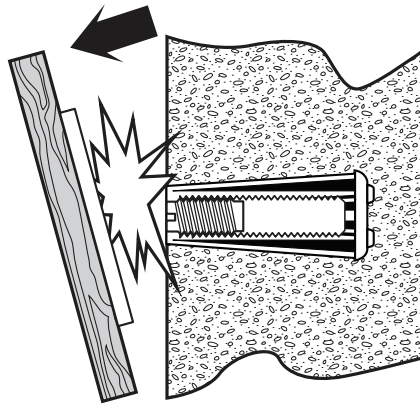

**2** Strip form.

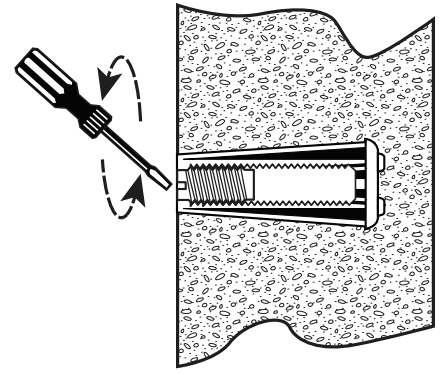

**3** Plug can be extracted with screwdriver

## TAP ON

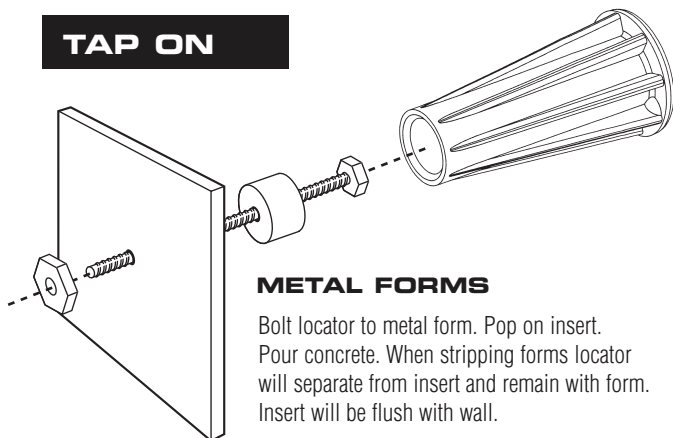

### METAL FORMS

Bolt locator to metal form. Pop on insert. Pour concrete. When stripping forms locator will separate from insert and remain with form. Insert will be flush with wall.

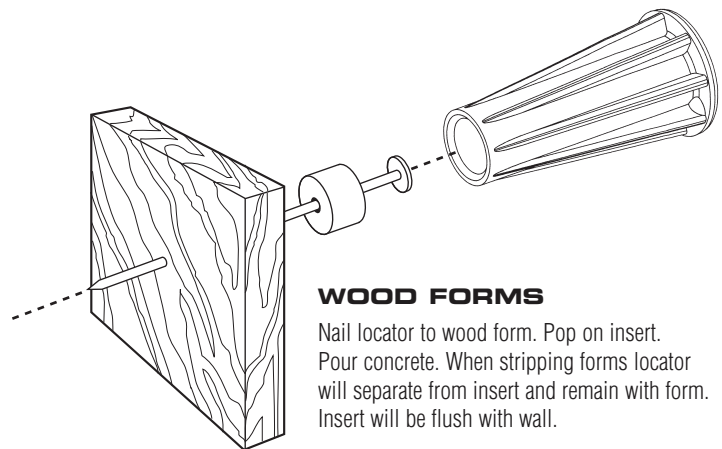

### WOOD FORMS

Nail locator to wood form. Pop on insert. Pour concrete. When stripping forms locator will separate from insert and remain with form. Insert will be flush with wall.